

IM-2 SE UNDERPINNER



!!! For your safety !!!
Read the instructions manual carefully



INTRODUCTION

Congratulation upon your purchase of the INMES IM-2 SE Underpinner, designed to fit your needs for finishing and productivity! We have developed this operations manual to help you install and use your machine correctly, in order to obtain the maximum benefit of economy and output. INMES is incorporating most advanced technology acquired during years of designing underpinners for the picture framing and furniture industry, sold all over the world. Your total satisfaction is our goal!!!

The IM-2 SE Underpinner brings in its project innovation, modern design, high performance of the equipment and the best cost/benefit ratio, at the same time introduces new system of loading the wedges.

The wedges in cartridges offer several benefits, such as:

- **Reduced Maintenance** - The wedges do not require glue.
- **Easy handle** - Using the cartridge wedges the operator will be able to change the wedges several times in a quick way without any waste, that way more productivity.
- **No waste** - it means that you use 100% wedges, best joining, high out put.
- **Quick identification** - the size of the wedges are identified by the colors of the cartridges.

Read the Operations Manual carefully in order make the best use of your new equipment.





Should you need further information please contact the INMES Distributor that you purchased the equipment or contact us at export_dept@inmes.com.br

INMES

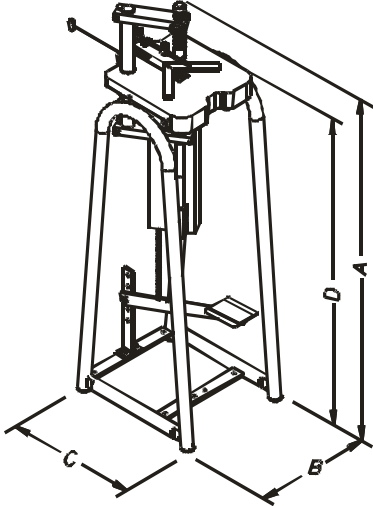

+55 (0) 48 658-2064

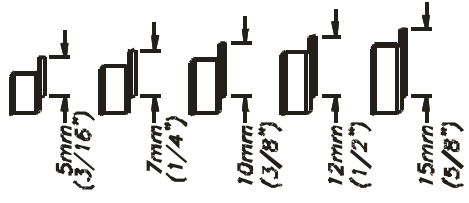
<http://www.inmes.com.br>

1 - TECHNICAL SPECIFICATIONS

 <p> A = 1180mm (46-7/16") B = 320mm (12-5/8") C = 370mm (14-9/16") D = 900mm (35-7/16") </p> <div style="text-align: center;">  16,6 Kg </div>	<p style="text-align: center;"><i>Its possible to use nails:</i></p> <div style="text-align: center;">  <p> 5mm (3/16") 7mm (1/4") 10mm (3/8") 12mm (1/2") 15mm (5/8") </p> <p style="text-align: center;">(Modelos "SW" e "HW")</p> </div> <hr/> <p style="text-align: center;"><i>Its possible to join profiles</i></p> <div style="text-align: center;">  </div> <p> L min. = 5mm (3/16") h min. = 8mm (5/16") L max. = 120mm (4-3/4") h max. = 110mm (4-1/4") </p>
--	--

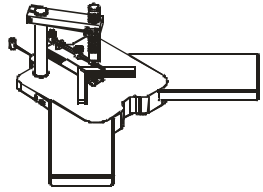
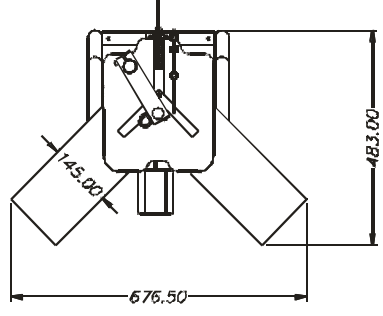
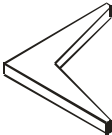
2 - ACCESSORIES

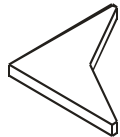
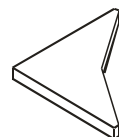
<p><i>Table extension IM-2</i></p>	
	
<p>CODE INMES 0101083</p>	
<p>Accessory Hexagonal</p> 	<p>Accessory Octagonal</p> 
<p>CODE INMES 0301001</p>	<p>CODE INMES 0301002</p>
<p>Accessory 12-sided</p> 	<p>Accessory 18-sided</p> 
<p>CODE INMES 0301086</p>	<p>CODE INMES 0301085</p>

3 - SAFETY INSTRUCTIONS

For operator safety and durability of your equipment, The instruction must be carried out with great care when installing and operating your machine, staying alert and learn how to use the IM-30 Plus.

3.1 - Avisos de segurança:



Warning - Means if the safety instruction is not followed could be seriously injured.



Danger - If the safety instruction is not followed the operator will be seriously injured.



Caution - Safety instruction if not carried out with care, might injury the operator.

3.2 - Before using the equipment

CAUTION

- ✓ Read the owner's manual before operating the equipment;
- ✓ The machine must be mounted on a flat surface in an appropriate work area, well lighted and enough air;

3.3 - Important information to reduce accidents

CAUTION

- ✓ Before starting the machine make sure that no objects have been left on the base;
- ✓ Use only original INMES parts in a good shape
- ✓ If any part is missing, bent or broken in any way, provide the proper maintenance;
- ✓ Keep children away from the equipment;
- ✓ Keep your hands away from the region the nail comes out (drive head assembly).

3.4 - After using the equipment

Clean it up and leave it ready for next use.

4 - UNPACKING AND CHECKING CONTENTS

As soon as you receive the IM-2 SE Underpinner, make sure that all parts are included.

The following parts are included:

- 01 Un. IM-2 SE Underpinner
- 01 Un. Allen 6mm
- 01 Un. Allen 5mm
- 01 Un. Allen 3mm
- 01 Un. Operations manual
- 01 Un. Bracket
- 01 Un. V01 Pressure Pad

5 - GETTING TO KNOW YOUR IM-2SE



Figura 01

- 01 - Bracket
- 02 - V01 Pressure Pad
- 03 - Moulding Guide
- 04 - Aluminum table top
- 05 - Drive head Assembly
- 06 - Base
- 07 - Pedal
- 08 -Upper Support
- 09 Pressure pad assembly Shaft
- 10 - Lower Support
- 11 - Chain Protection
- 12 - Chain

6 - INSTALLING THE IM-2 SE UNDERPINNER

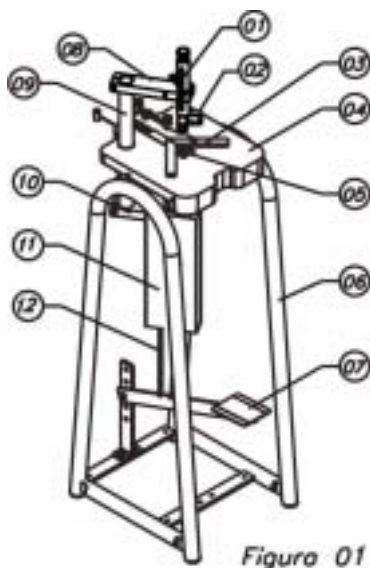

Figura 02

- ✓ The IM-2 SE Underpinner must be mounted on a flat surface in an appropriate work area, well lighted and enough air;

The IM-2 SE comes with holes to be fixed on the floor as shown figure 02. To fix it on the floor use four (4) screws with bushing in size of "8" (those screws and bushing are not included with the machine)

After fixing the IM-2 SE on the floor, install the guide bar, Fig. 03 (01).

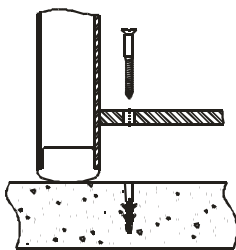
- 1) Remove the screw Fig. 03 (02)
- 2) Press the button, Fig. 03 (05)
- 3) Place the bracket, Fig. 03 (01) on the upper support, Fig. 03 (04)
- 4) Release the button, Fig. 03 (05)
- 5) Place the screw, Fig. 03 (02)
- 6) Place the V01 pressure pad, Fig. 03 (03)



Figura 03

7- OPERATIONS

7.1 - Selecting the appropriate nail

Identify the format and the density of the profile; select the type and the size of the nail to be applied

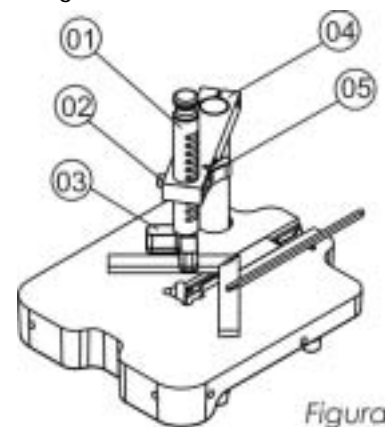
For profiles with low density (**soft wood**), you must use nails "SW" INMES

For profiles with high density (**hard wood**), you must use nails "HW" INMES

PS: INMES has wedges in sizes of 3/16", 1/4", 3/8", 1/2", 5/8" (5,7,10,12,15mm) "SW" and "HW" packed in disposable cartridges for using on IM-2 SE Underpinner.

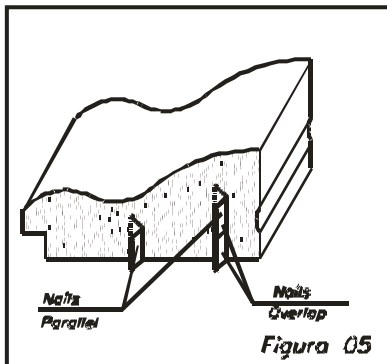

According to the format of the profile, choose the size of the nail to be applied.

The nail that you chose it's not supposed to be bigger than the profile, as shown fig. 04.

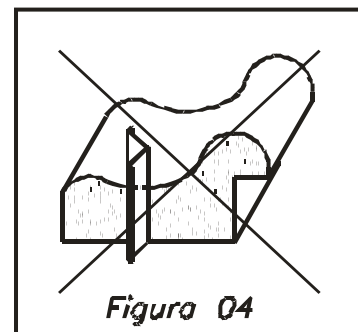

In order to apply two (2) or more nails, one on top of the other, Fig. (5), it's necessary the operator press the pedal twice or more according to your needs, and make sure not to move the profile during the operation.

7.2 - Selecting the appropriate cartridge

The selected nail will identify the cartridge to be inserted into the machine. In order to do that you must check if the size of the nail chosen by you is the same indicated on top of the cartridge, according to the Fig. 06. We also can identify the cartridge through the colors.



Figura 06

7.3 - Placing the cartridge into the IM-2 Underpinner

To insert the cartridge you have to proceed with the following steps:

- 1) Remove the Moulding Guide, Fig. 07 (01);
- 2) Spring-Loaded Cable;;
- 3) Fit the cartridge, Fig. 07 (03);
- 4) Release the cartridge, Fig. 07 (02);
- 5) Replace the Moulding Guide Fig. 07 (01) in it's place.

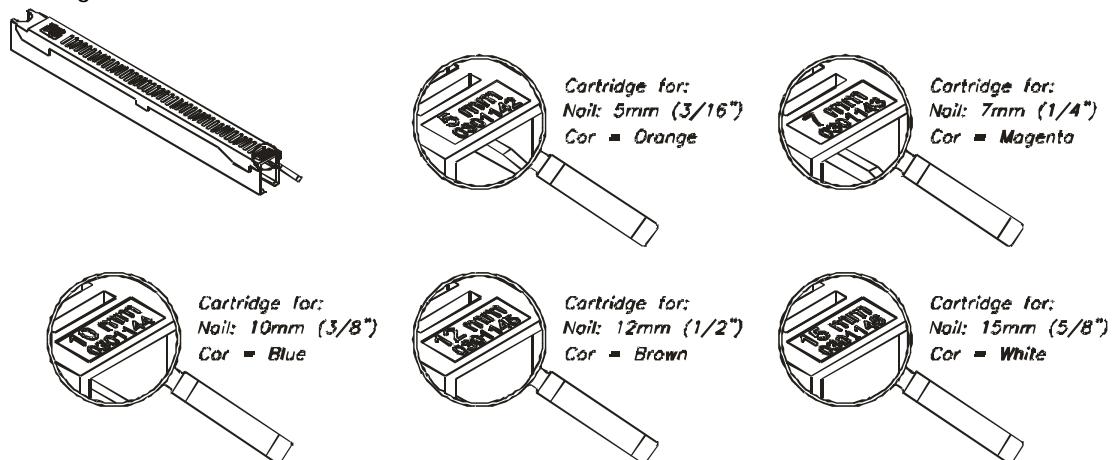

Figura 07

7.4 - The distance between the nails

Depending on the type of the profile its necessary to use one or more nails for joining.

7.4.1 - When using just one Nail

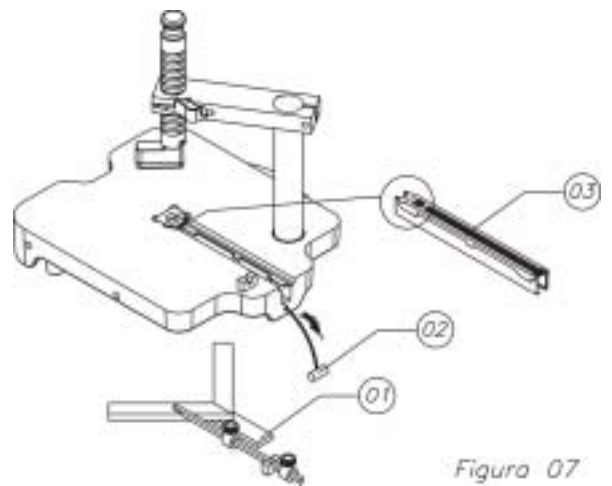
It's recommended to insert the nail in the central position of the profile, as shown Fig. 08



Figura 08

7.4.2 - Two or more Nails

In order to apply two or more nails you must adjust the Moulding Guide through the lock screws as shown Fig. 08 (01 and 02).

The distance "D" between the lock screws represents the distance "A" between the nails.

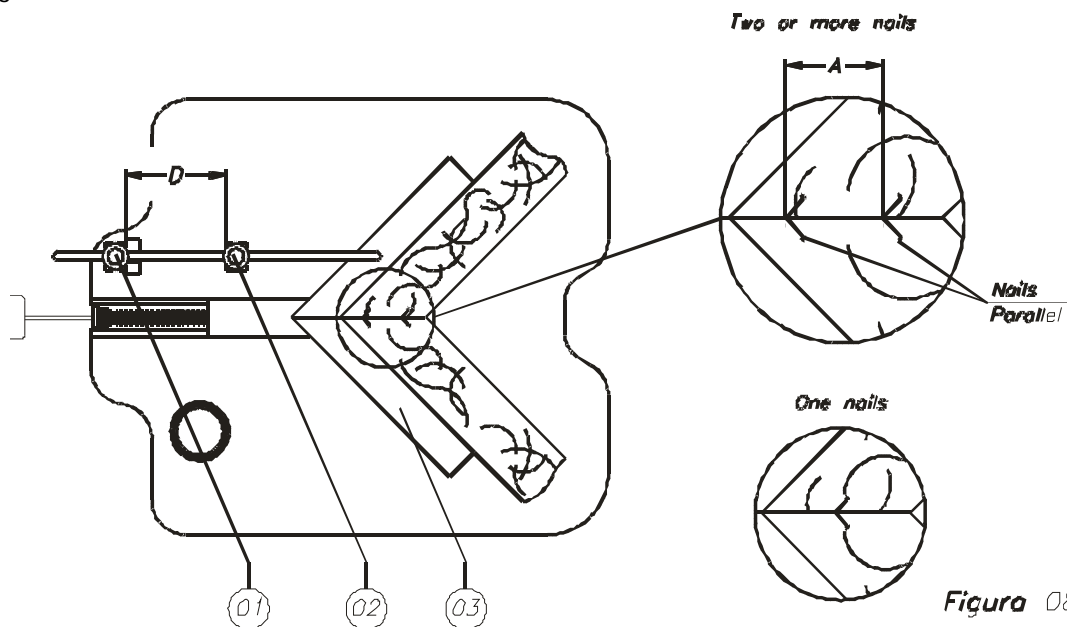
We recommend to positioning the nails according to the figure 09 (A) in order to obtain a perfect joining.

Never make the joining as shown figure 09 (B), that way the nail might damage the profile.



Figura 09

7.5 - Adjustment of the Guide Bar

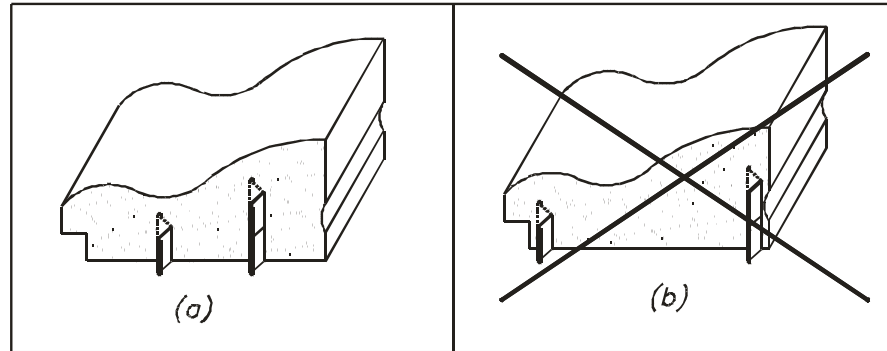

Figura 10

We recommend setting the Guide Bar Fig. 10 (01) approximately 3/8" (10mm) from the upper part of the profile as shown figure 10

To adjust the Guide Bar proceed as follow:

- 1) Press the button Fig. 10 (02);
- 2) Positioning the Guide Bar Fig. 10 (01) (observe the distance recommended);
- 3) Release the button Fig. 10 (02).

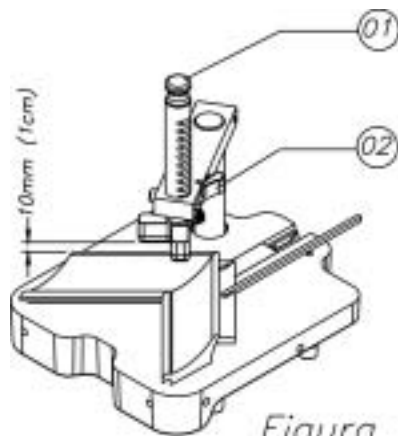
7.6 - Joining

Make sure the prior advices were followed correctly, before making the joining.

For joining proceed as follow:

- 1) Place the profile, Fig. 11 (02)
- 2) Simultaneously hold the profiles firmly against the moulding guide in the way of the narrows (A) and (B); and press the foot pedal until the end of the course.



Figura 11

CAUTION

- ✓ Never place your hands between the Guide Bar Fig. 10 (01) and the profile, when joining.

For joining large pictures frames, the operator can use the rear position of the IM-2 SE Underpinner or using the accessory Table Extension, page 03

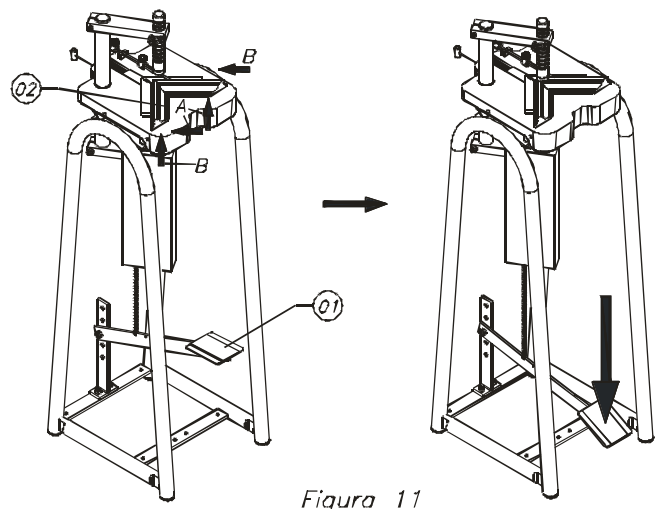
To operate the IM-2 rear position its necessary to change the pedal from the front position to the rear position of the equipment as show figure 12.



Figura 12

To change the pedal position its necessary proceed as follow:

- 1) Release the screws from the pedal's support figure 12 (02);
- 2) Release the connection of the chain, figure 12 (03);
- 3) Place de pedal in front position Fig. 12 (04).

8 - MAINTENANCE

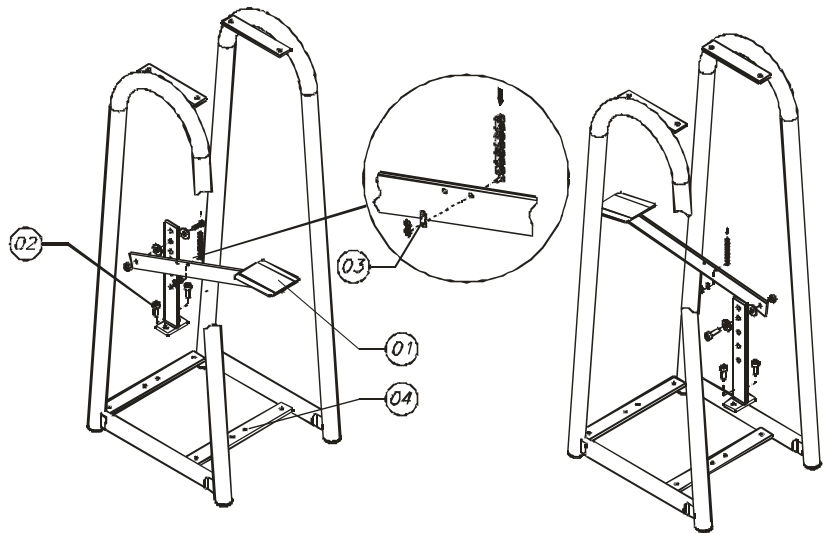
Important:

- ✓ I order to obtain the best cost/benefit ratio use only INMES original parts.

- **Lubrication** - All moving parts should be lubricated after every 40 working hours use MOLYCOTE BR 2 or similar product;
- **Location** - The IM-2SE Underpinner should be protected from weather, humidity, dust, etc...;
- **Cleaning** - Periodically you should clean the drive head assembly. Wash it with warm water, wipe thoroughly, then put a drop of sewing machine oil on the drive rod before reassembling.

8.1 - Replacing the nail driver rod



Figura 13

Replace it by following the following procedure:

- 1) Remove bolt Fig. 13 (03);
- 2) Pull the assembly head up through the top of the table;
- 3) Remove the screws Fig. 13 (08) and the ring Fig. 13 (05);
- 4) Pull the drive rod Fig. 13 (04). PS: if the drive rod get stuck inside the Assembly head, the assembly head must be opened, remove the four (04) screws Fig. 13 (01) using Allen 3mm and take the drive rod out;
- 5) Place the new one in the head;
- 6) Place the ring Fig. 13 (05);
- 7) With the hole at the bottom to receive bolt Fig. 13 (08). After reassembling, make sure the drive rod moves freely up and down;
- 8) The assembly head and drive rod should be cleaned periodically with warm water, no soap in order to remove the glue applied to the joints of the frames;
- 9) When putting the head back on the machine, be sure it is level with the top of the table, and that the drive rod continues to move freely.
- 10) Place the bolt Fig. 13 (03).

Never use a hammer to make maintenance

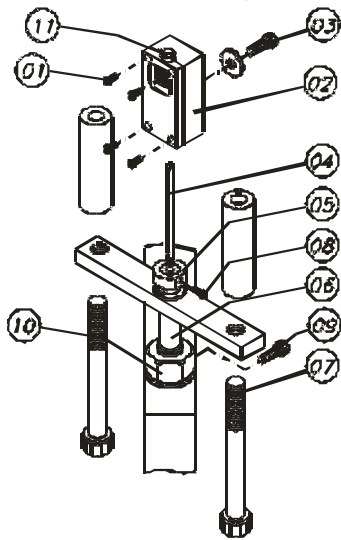
8.2 - Drive Rod Stuck

8.2.1 - In case the Drive Rod Get Stuck

Proceed as follow:;

- 1) Release the bolt, Fig. 13 (07);
- 2) Pull up the Upper support with your hands, Fig. 03 (03) page 05;
- 3) Get help from someone else and tighten the bolt, Fig. 17 (07).

8.2.2 - Adjusting the height of the Drive

To adjust the height of the Drive Rod proceed as follow:

- 1) Remove the bolt, Fig. 13 (09);
- 2) Adjust the Drive Rod level with the top of the table, fig. 13 (04) rotating the nut to the clockwise direction to raise the Drive rod, or rotating the nut to the counter clockwise direction to low the Drive Rod;
- 3) Place the bolt, fig. 13 (09).

9 - TROUBLESHOOTING

TROUBLE	POSSIBLE CAUSE	REMEDY
It does not insert the nail	The height to the Guide bar is not adjusted correctly	Check if the Guide Bar is adjusted according to recommended in manual (see item 7.5 page 08).
	Cartridge positioned into wrong way	Make sure the cartridge has been fit correctly
Nail get stuck in the assembly drive head	Excess of glue	Remove the Assembly Drive Head and wash it with warm water and lubricate, after that replace it again.
	Cartridge positioned into wrong way	Make sure the cartridge has been fit correctly
The nail insertion is irregular	Height of the Drive Rod	Adjust the height of the Drive Rod according to the instructions in the manual (see item 8.2.2 page 10).
	Insufficient course of the pedal	Press the pedal until the end of the course. Make sure the height of the Guide Bar is adjusted as we recommended in the manual (see item 7.5 page 08).
Profile opens after joining	Make sure you are choosing the right size of the nail	Use the right size
	Crooked profile	Check out the cut
The Guide bar does not return to its original position	Lubrication	Lubricate the moving parts with MOLYCOTE BR 2 or similar product

10- PARTS LIST FOR IM-2 SE UNDERPINNER

<i>CODE</i>	<i>DESCRIPTIONS</i>	<i>CODE</i>	<i>DESCRIPTIONS</i>
<i>INM03010003</i>	<i>Base for positioning stops IM-2</i>	<i>INM04080030</i>	<i>Bolt M8X40mm</i>
<i>INM03010004</i>	<i>Moulding guide IM-2</i>	<i>INM04080037</i>	<i>Bolt M10X25mm</i>
<i>INM03010006</i>	<i>Bushing IM-2</i>	<i>INM04080046</i>	<i>Bolt M10X90mm</i>
<i>INM03010011</i>	<i>Guide Bar</i>	<i>INM04080069</i>	<i>Nut M10</i>
<i>INM03010013</i>	<i>Nut M16 IM-2</i>	<i>INM04080075</i>	<i>Allen wrench 5mm</i>
<i>INM03010014</i>	<i>Chain's protector IM-2</i>	<i>INM07080076</i>	<i>Allen wrench 6mm</i>
<i>INM03010015</i>	<i>Chain's guide IM-2</i>	<i>INM04080113</i>	<i>Bolt M4X12mm</i>
<i>INM03010022</i>	<i>Lower support IM-2</i>	<i>INM04080144</i>	<i>Steel rivet 3.2x10.2mm</i>
<i>INM03010038</i>	<i>Bolt M5 IM-2</i>	<i>INM04080155</i>	<i>Allen wrench 3mm</i>
<i>INM03010042</i>	<i>Shaft IM-2</i>	<i>INM04080160</i>	<i>Nut M4</i>
<i>INM03010044</i>	<i>Bushing</i>	<i>INM04080205</i>	<i>Allen wrench 8mm</i>
<i>INM03010054</i>	<i>Main shaft washer</i>	<i>INM04080258</i>	<i>Wrench 17x19mm</i>
<i>INM03010060</i>	<i>Anti-sliding sticker</i>	<i>INM04160012</i>	<i>Spring</i>
<i>INM03010068</i>	<i>IM-2 base</i>	<i>INM04160001</i>	<i>Spring IM-2</i>
<i>INM03010081</i>	<i>Moulding guide and Teflon pad IM-2</i>	<i>INM04170008</i>	<i>Flex pin 4x24mm</i>
<i>INM03010087</i>	<i>Guide for drive piston IM-2</i>	<i>INM04170009</i>	<i>Flex pin 3x36mm</i>
<i>INM03010141</i>	<i>Polyurethane pressure pad</i>	<i>INM04170010</i>	<i>Flex pin 6x24mm</i>
<i>INM03010202</i>	<i>Aluminum table top</i>	<i>INM04170011</i>	<i>Flex pin 6x36mm</i>
<i>INM03010211</i>	<i>Main shaft IM-2/IM-3/3P</i>	<i>INM04170092</i>	<i>Driver Pin DIN 7.5x16mm</i>
<i>INM03010212</i>	<i>Chain IM-2/IM-3</i>	<i>INM05040237</i>	<i>Manual</i>
<i>INM03010397</i>	<i>FootPedal IM-2/IM-3</i>	<i>INMP03010005</i>	<i>Bushing IM-2</i>
<i>INM03010398</i>	<i>Foot pedal support IM-2/IM3</i>	<i>INMP03010028</i>	<i>Position Stop IM-2</i>
<i>INM03010600</i>	<i>Bracket</i>	<i>INMP03010051</i>	<i>Spring loaded cable IM-2</i>
<i>INM03010601</i>	<i>Pin Button</i>	<i>INMP03010066</i>	<i>Wedge shoe IM-2</i>
<i>INM03010602</i>	<i>Screw M8</i>	<i>INMP03010164</i>	<i>Bushing IM-2/ IM-3/3P</i>
<i>INM03010604</i>	<i>Upper Support IM-2/IM-3/IM-3P</i>	<i>7006A</i>	<i>Drive rod IM-2</i>
<i>INM03010606</i>	<i>Button</i>	<i>INMP03010200</i>	<i>Drive head assemblyIM-2/IM-3/3P</i>
<i>INM04050031</i>	<i>Label</i>	<i>INMP03010208</i>	<i>Bushing IM-2/IM-3/3Pi</i>
<i>INM04050120</i>	<i>Label</i>	<i>INMP03020249</i>	<i>Arruela Proteção Lâmina IM-300</i>
<i>INM04050121</i>	<i>Label</i>	<i>7147</i>	<i>V01 Pressure Pad</i>
<i>INM04080007</i>	<i>Bolt M4X10mm</i>	<i>7148</i>	<i>V02 Pressure Pad</i>
<i>INM04080008</i>	<i>Bolt M4X16mm</i>	<i>7149</i>	<i>V03 Pressure Pad</i>
<i>INM04080009</i>	<i>Bolt M4X20mm</i>	<i>7150</i>	<i>Round Pressure Pad D50mm</i>
<i>INM04080012</i>	<i>Bolt M5X08mm</i>	<i>7151</i>	<i>Round Pressure Pad D25mm</i>
<i>INM04080018</i>	<i>Bolt M6X20mm</i>	<i>INMP04080016</i>	<i>Bolt M6X16mm</i>
<i>INM04080025</i>	<i>Bolt M8X16mm</i>	<i>INMP04150001</i>	<i>Manipulo Borboleta M6x10</i>
<i>INM04080029</i>	<i>Bolt M4X40mm</i>	<i>INMP04160002</i>	<i>Spring IM-2</i>

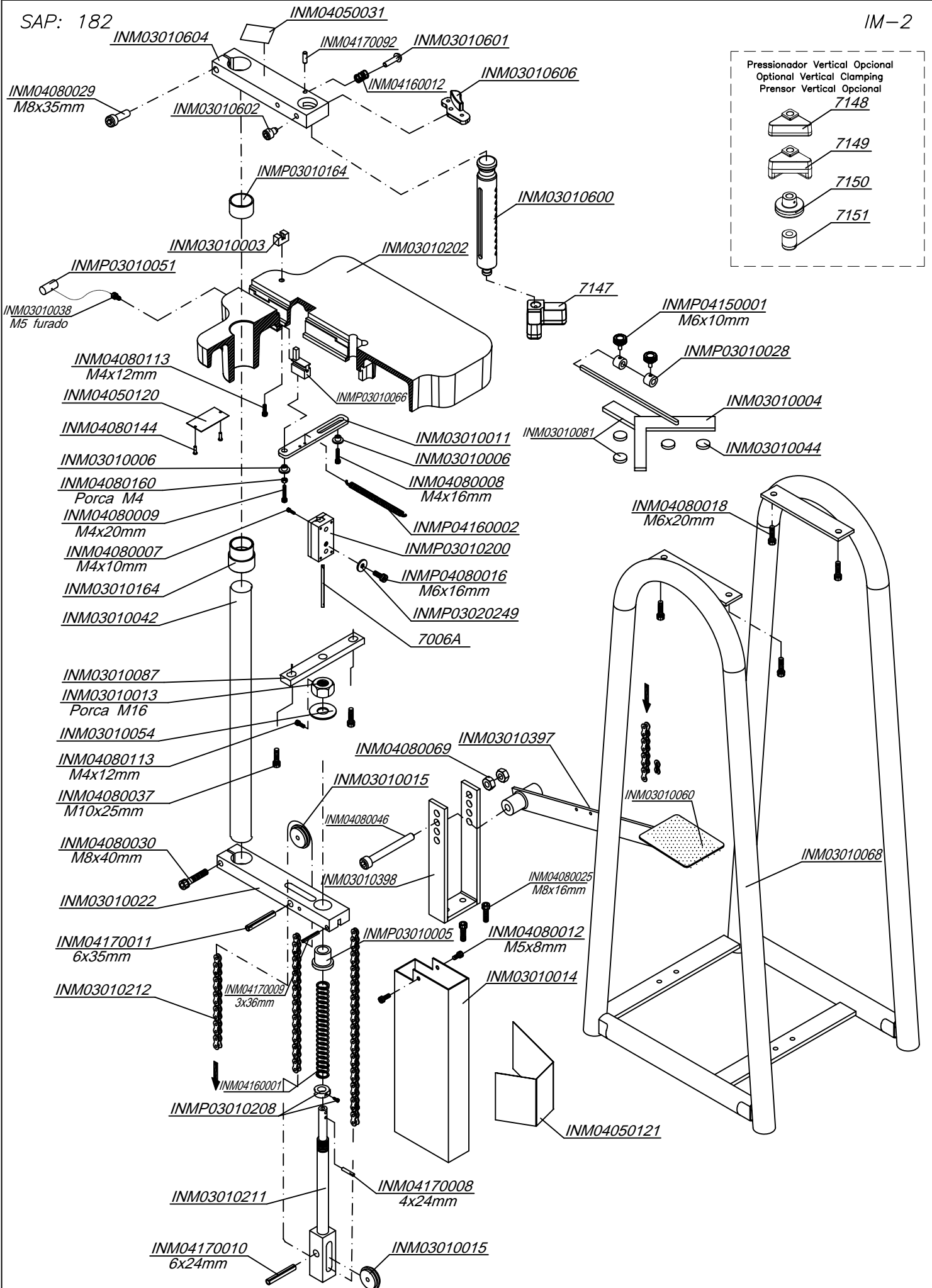

Samples of frames you can assembly with the IM-2 SE underpinner, when you have the accessories contact the distributor near you!

Accessories code

- 0301001 to hexagonal frames*
- 0301002 to octagonal frames*
- 0301085 to 18 sides frames*
- 0301086 to 12 sides frames*

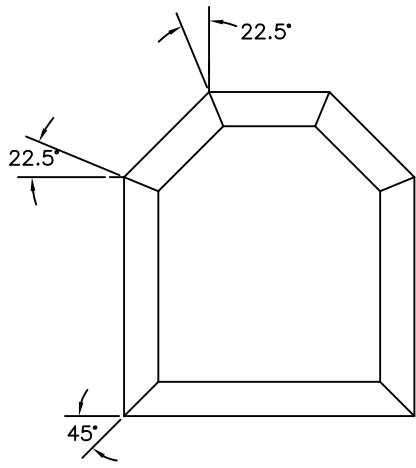

Octagonal - square

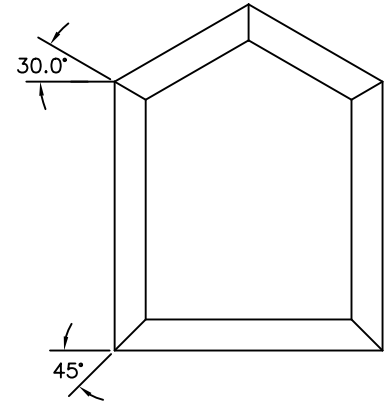

Hexagonal - square

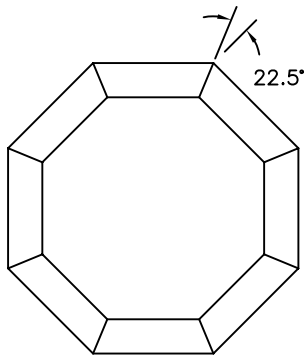

Octagonal

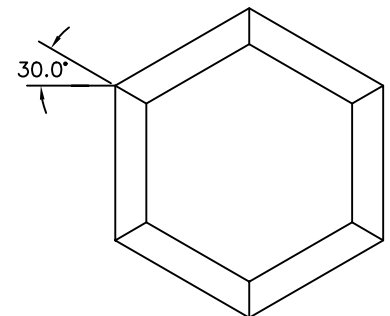

Hexagonal

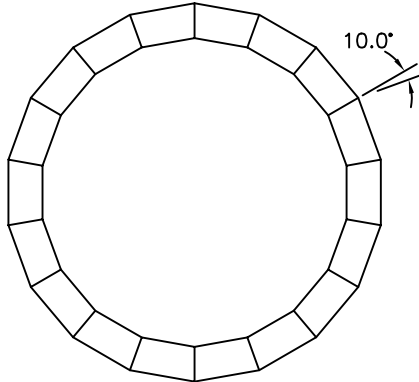

18 Sides

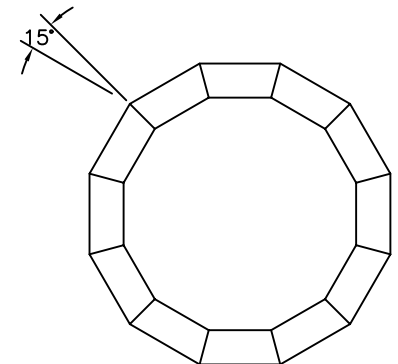

12 Sides

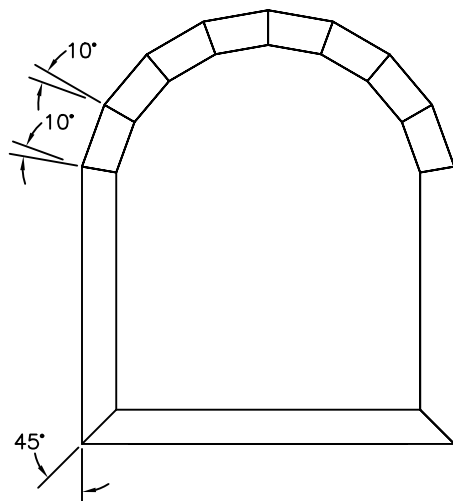

18 Sides - square

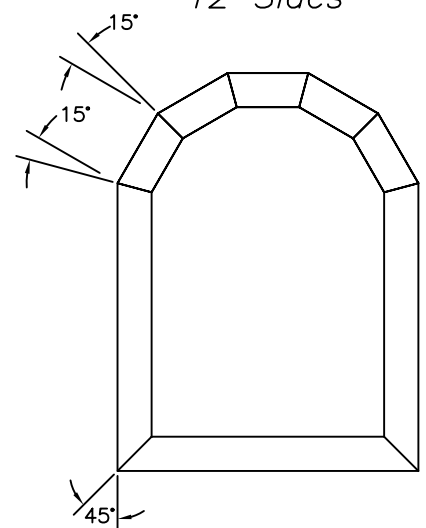

12 Sides - square



INMES

Rod. SC 438 - Km 184
Caixa Postal 65 - CEP 88750-000
Braço do Norte - SC - Brasil
<http://www.inmes.com.br>
e-mail: vendas@inmes.com.br
SAC 0300 788 2022
+55 (48) 3658 3702